

Rax

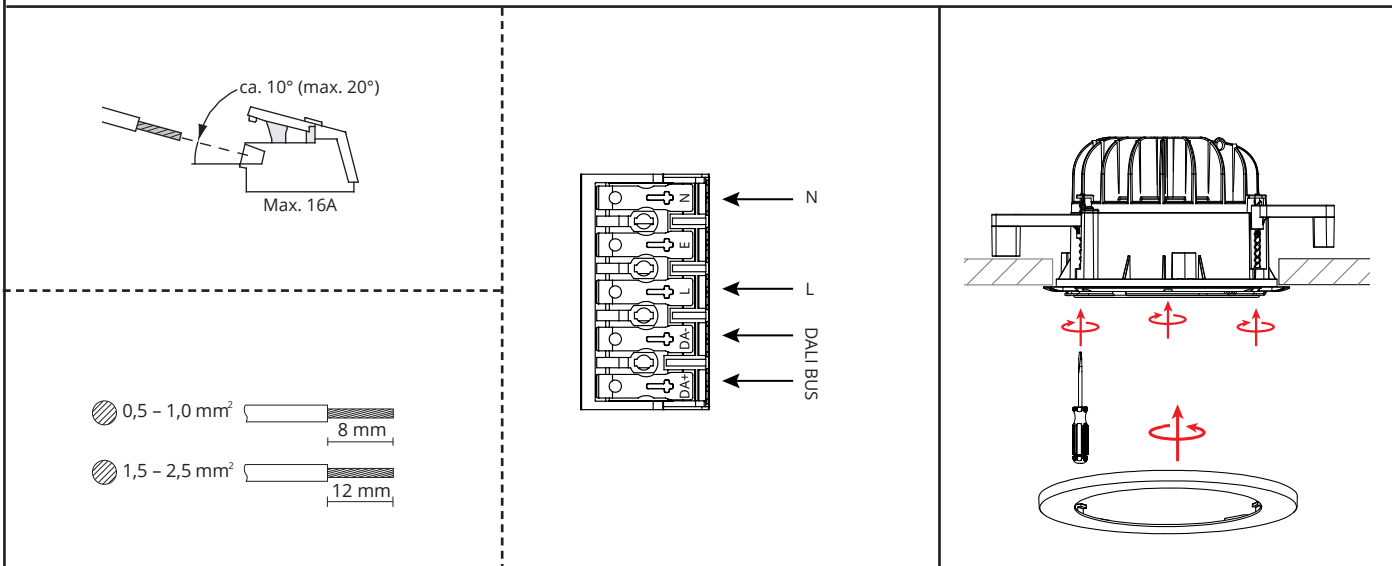

230V, 50/60Hz, 19W

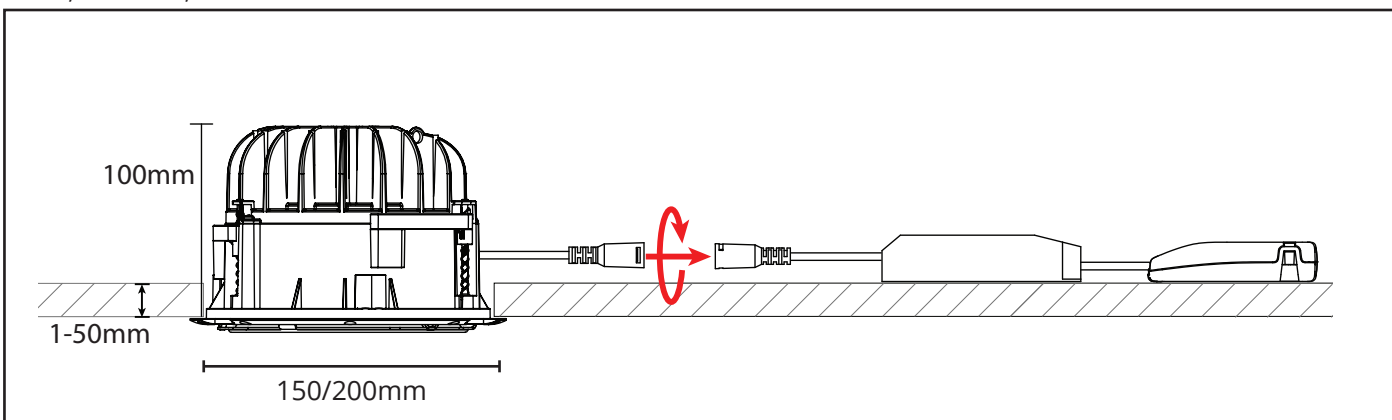

NO: Kan kun installeres og vedlikeholdes av en registrert installasjonsvirksomhet.

DK: Må kun installeres og vedligeholdes af uddannet elektriker.

SE: Skall installeras och underhållas av behörig elektriker.

EN: Only to be installed and maintained by an authorized electrician.

FR: Doit être installé et maintenu par un électricien qualifié.

NL: Mag alleen geïnstalleerd en onderhouden worden door een bevoegde elektricien.

DE: Dieses Produkt darf nur durch autorisiertes Personal (z.B. Elektro-Installateur) angeschlossen, in Betrieb genommen und gewartet werden.

FI: Asentaa ja huoltaa saa vain valtuutettu sähköasentaja



NO: Skru av strømmen før montering.

DK: Sluk for strømmen inden montering.

SE: Stäng av strömmen innan montering.

EN: Turn off power before installing.

FR: Couper le courant avant l'installation.

NL: Stroom uitschakelen voor u het toestel installeert.

DE: Vor Installationsarbeiten den Strom abschalten.

FI: Sammuta virta ennen kytkemistä



NO: Armaturen må ikke tildekkes av isolasjon

DA: Armaturen må ikke dækkes af isolering

SE: Armaturen får inte täckas av isolering

EN: Luminaire not suitable for covering with thermally insulating material

FR: Ne pas couvrir les luminaires avec du matériel d'isolation thermique

NL: Armaturen mogen niet met warmte-isolerend materiaal afgedekt worden

DE: Leuchten dürfen nicht mit wärmedämmendem Material abgedeckt werden

FI: Valaisinta ei saa peittää!

NORWAY

SG Armaturen AS

Skytterheia 25
N-4790 Lillesand

Tel: +47 37 50 03 00
firmapost@sg-as.no
www.sg-as.no

SWEDEN

SG Armaturen AB
Tel: +46 31 81 71 10
info@sg-ab.se
www.sg-ab.se

FINLAND

SG Armaturen Oy
info@sg-oy.fi
www.sg-oy.fi

DENMARK

SG Armaturen A/S
Tel: +45 70 70 72 13
info@sg-as.dk
www.sg-as.dk

UNITED KINGDOM

SG Lighting LTD
Tel: +47 37 50 03 00
info@sighting.co.uk
www.sighting.co.uk

FRANCE

SG Lighting SA/NV
Tel: +33(0) 4 94 93 00 00
info.france@sighting.fr
www.sighting.net

BENELUX

SG Lighting SA/NV
Tel: +32(0) 15 20 72 71
info.benelux@sighting.net
www.sighting.net

GERMANY

SG Leuchten GmbH
Tel: +49 40 23 99 44 59
info@sg-leuchten.de
www.sg-leuchten.de

INTERNATIONAL

SG Lighting Co Ltd.
Tel: +86 769 88 49 20 88
cindy@sgdgc.com
www.sg-as.com

Dipswitch

	mA	lm
<input type="checkbox"/> ON 	250	52%
<input type="checkbox"/> ON 	300	62%
<input type="checkbox"/> ON 	350	74%
<input type="checkbox"/> ON 	400	84%
<input type="checkbox"/> ON 	450	93%
<input type="checkbox"/> ON 	500	100%
<input type="checkbox"/> ON 	550	109%
<input type="checkbox"/> ON 	600	118%
<input type="checkbox"/> ON 	650	129%
<input type="checkbox"/> ON 	700	139%

Standard

